

Lanolinx LNX-800N

8-Port 10/100BaseTX Managed Industrial Switch



Features

- ▶ Web Browser Configuration for Easy Setup
- ▶ Ethernet Ring Redundancy (Recovery Time <300ms)
- ▶ IEEE 802.1w Rapid Spanning Tree & IEEE 802.1d Spanning Tree Protocol
- ▶ IGMP with Query Mode for Multi-Media Applications
- ▶ Supports Port Based VLAN & IEEE 802.1Q Tag VLAN
- ▶ IEEE 802.1p Class of Service for Traffic Classification & Prioritization
- ▶ Port Mirroring for Traffic Monitoring
- ▶ Ingress/Egress Rate Control for Bandwidth Optimization
- ▶ Broadcast Storm Protection
- ▶ Supports SNMP and SNMP Trap
- ▶ IP Address Security Management to Prevent Unauthorized Access
- ▶ Automatic Warnings by Exception Through E-mail or Relay Output
- ▶ Supports STMP, SMTP, DHCP Client Protocols
- ▶ Dual Redundant DC Power Inputs
- ▶ IP30 Rugged Aluminum Case Design
- ▶ Extended Operating Temperature (-40°C to 80°C) for Harsh Environments
- ▶ DIN-Rail or Panel Mountable for Easy Installation



▶ Dimensions (unit = mm)

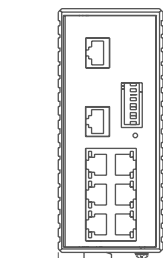

Front View

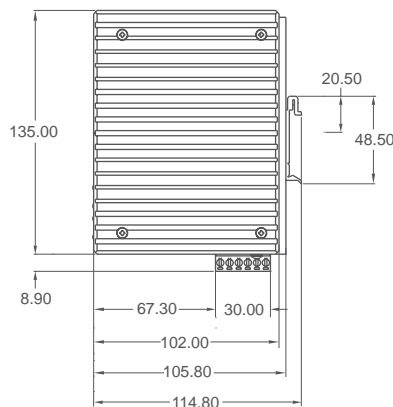

Side View

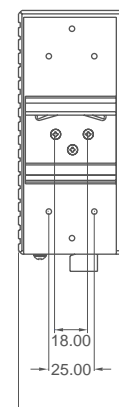

Back View

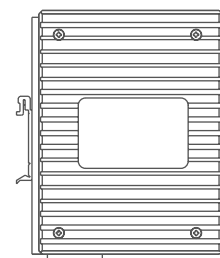

Side View

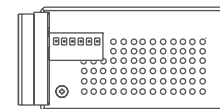

Bottom View

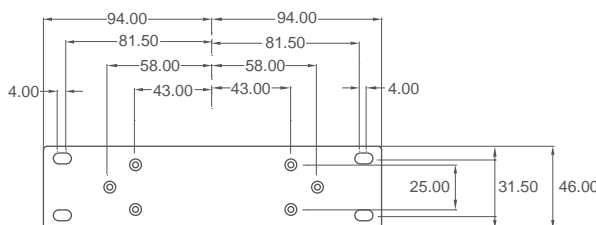

Back Plate



Top View

► Specifications

Standard

IEEE 802.3 10BaseT Ethernet
IEEE 802.3u 100BaseTX Fast Ethernet
IEEE 802.3x Flow Control and Back-Pressure
IEEE 802.1d Spanning Tree
IEEE 802.1w Rapid Spanning Tree
IEEE 802.1p Class of Service
IEEE 802.1Q VLAN Tag

Management

Provides SNMP, Web Interface Management

SNMP MIB

RFC1213 MIB-II, RFC1493 Bridge MIB, RMON RFC1757, RFC2674
VLAN MIB, RFC1643 Ethernet like MIB, RFC1215 Trap MIB, IGMP MIB,
Private MIB

SNMP Trap

Up to 3 Trap Stations

Protocol

CSMA/CD

Switch Architecture

Store and Forward

Transfer Rate

14,880pps for Ethernet Port
148,800pps for Fast Ethernet Port

Transfer Packet Size

64 bytes to 1522 bytes (with VLAN Tag)

Packet Filter

4 rules for different types of packet combinations

MAC Address

2K MAC Address Table

Memory Buffer

1Mb

LED

Unit: Master, Power, Power 1, Power 2, Fault
Port: Link/Activity, Full-Duplex/Collision

Network Cable

10BaseT: 2-pair UTP/STP Cat. 3, 4, 5 cable EIA/TIA-568 100-ohm (100m)
100BaseTX: 2-pair UTP/STP Cat. 5 cable EIA/TIA-568 100-ohm (100m)

Back-Plane

1.6 Gbps

Packet Throughput Ability

2.38Mpps @ 64bytes (8TX)

Redundant Ring

2 Ports for Ring Redundancy (< 300 ms recovery time)
Supports Dual Homing & Ring Coupling

VLAN

Port Based & IEEE 802.1Q Tag VLAN. Group up to 64 VLANs

Class of Service

Provides 4 priority queues per port

Quality of Service

Port Based, Tag Based, & IPv4 Type of Service

IGMP

IGMP v1 and Query Mode. Up to 256 groups

Spanning Tree

IEEE 802.1d Spanning Tree
IEEE 802.1w Rapid Spanning Tree

SNTP

Supports Simple Network Time Protocol

SMTP

Supports Simple Mail Transfer Protocol

Management IP Security

Supports up to 10 IP Addresses for Secured Access

System Event Log

1000 Event Log entries available

Port Mirror

Supports TX packet only or TX & RX packets

Firmware Update

Supports TFTP Firmware Update

DHCP Client

Provides DHCP Client function to obtain IP Address from DHCP Server

Bandwidth Control

Supports Ingress and Egress packet limit

Alarm

Provides 1 relay output (1A @ 24VDC) for port breakdown and power fail

Power Supply

Input Voltage: 12 to 48 VDC & 1 DC jack for AC/DC Power Adapter
2 sets of wide range DC power with reverse polarity protection

Power Consumption

4.6 Watts

Mechanical

Casing: IP30 Metal Case
Dimension (W x H x D): 58 x 135 x 105.8 mm (2.28 x 5.31 x 4.17 in.)
Installation: DIN-Rail/Wall Mountable

Weight

Unit Weight: 1.5 lbs.
Shipping Weight: 2.3 lbs.

Operation Temperature

Standard: -10° C to 70° C (14° F to 158° F)
Wide Operating Temperature: -40° C to 80° C (-40° F to 176° F)

Operation Humidity

5% to 95% (Non-condensing)

Storage Temperature

-40° C to 85° C

EMI

FCC Class A
CE EN6100-4-2/EN6100-4-3/EN6100-4-4/EN6100-4-5/EN6100-4-6

Safety

UL, cUL, CE EN60950

Stability Testing

Shock: IEC60068-2-27
Free Fall: IEC60068-2-32
Vibration: IEC60068-2-6

Warranty

5-Year Warranty

► Ordering Information

LNX-800N
LNX-800N-T

8-Port 10/100BaseTX Industrial Ethernet Switch with Redundant Ring, Managed
8-Port 10/100BaseTX Industrial Ethernet Switch with Redundant Ring, Managed, Wide Operating Temperature

Optional Accessories

DR-4524 45W 24VDC Industrial DIN Rail Power Supply
DR-75-24 75W 24VDC Industrial DIN Rail Power Supply
DR-120-24 120W 24VDC Industrial DIN Rail Power Supply

Aaxeon Technologies, Inc.

445 Capricorn St.
Brea, CA 92821
USA

Toll-Free: (877) AAXEON5 (229-3665)
Phone: (714) 671-9000
FAX: (714) 671-9944
e-Mail: info@aaxeon.com

aaxeon[®]
www.aaxeon.com